

TOSHIBA Bi-CMOS Integrated Circuit Silicon Monolithic

# TB6586FG, TB6586AFG

Three-Phase Full-Wave Brushless Motor Controller

## Features

- Upper-phase PWM control
- Built-in triangular-wave generator
- Support of a bootstrap circuit
- Built-in Hall amplifier (support of a Hall element)
- Selectable 120°/150° energization
- Built-in lead angle control function
- Overcurrent protection signal input pin ( $V_{RS} = 0.5 \text{ V (typ.)}$ )
- Built-in regulator ( $V_{\text{refout}} = 5 \text{ V (typ.)}$ , 35 mA (max))
- Operating supply voltage range:  $V_{CC} = 6.5 \text{ to } 16.5 \text{ V}$ ,  $V_M = 4.5 \text{ to } 16.5 \text{ V}$
- The TB6586FG and TB6586AFG differ in the number of pulses per revolution:
  - TB6586FG: 1 pulse / electrical angle: 360°
  - TB6586AFG: 3 pulses / electrical angle: 360°

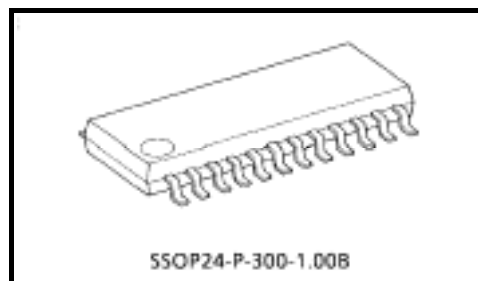

Weight: 0.27 g (typ.)

About solderability, following conditions were confirmed

- Solderability
  - (1) Use of Sn-37Pb solder Bath
    - solder bath temperature = 230°C
    - dipping time = 5 seconds
    - the number of times = once
    - use of R-type flux
  - (2) Use of Sn-3.0Ag-0.5Cu solder Bath
    - solder bath temperature = 245°C
    - dipping time = 5 seconds
    - the number of times = once
    - use of R-type flux

## Pin Description

Pin No.	Symbol	Description
1	V <sub>SP</sub>	Speed control
2	HUP	U-phase Hall signal input (+) pin
3	HUM	U-phase Hall signal input (-) pin
4	HVP	V-phase Hall signal input (+) pin
5	HVM	V-phase Hall signal input (-) pin
6	HWP	W-phase Hall signal input (+) pin
7	HWM	W-phase Hall signal input (-) pin
8	V <sub>refout</sub>	Outputs reference voltage signal (5 V / 35 mA)
9	LA	Lead angle setting signal input pin (30° / 4 bits)
10	GND	Ground pin
11	CW/CCW	Rotation direction signal input pin
12	OSC/C	Connect to condenser for PWM oscillator
13	OSC/R	Connect to resistor for PWM oscillator
14	RS	Overcurrent protection (0.5 V)
15	RESET	Energization width toggle pin (Low: 150°, High; Reset, 6.35 V: 120°)
16	V <sub>CC</sub>	Power supply
17	V <sub>M</sub>	Input for output power
18	UL	U-phase output pin (Low)
19	VL	V-phase output pin (Low)
20	WL	W-phase output pin (Low)
21	UH	U-phase output pin (Low)
22	VH	V-phase output pin (Low)
23	WH	W-phase output pin (Low)
24	FG	Output of number of pulses per revolution (FG: 1 pulse / electrical angle; AFG: 3 pulses / electrical angle)

## Pin Layout

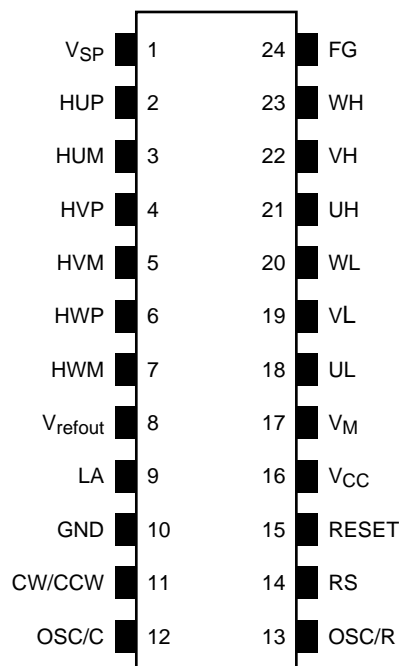

**Input/Output Equivalent Circuits**

Pin Description	Symbol	Input/Output Signal	Input/Output Internal Circuit
Positional signal input pin	HUP HUM HVP HVM HWP HWM	Analog/Digital  Hysteresis $\pm 7.5$ mV (typ.)	
Speed control signal input pin	VSP	Analog  Input range 0 to 7 V	
Rotation direction signal input pin  L: Forward (CW) H: Reverse (CCW)	CW/CCW	Digital  L: 0.8 V (max) H: Vrefout - 1 V (min)  ( Test input If CW/CCW = 6.35 V (typ.) or higher, the system resets )  Hysteresis 150 mV (typ.)	
Reset input  L: 150° turn-on mode H: Reset	RESET	Digital  L: 0.8 V (max) H: Vrefout - 1 V (min)  If RESET = 6.35 V (typ.) or higher, then 120° energization drive is selected  Hysteresis 150 mV (typ.)  During a reset: Output OFF (all phases Low). The internal counter continues to operate.	
Lead angle setting signal input	LA	Analog  Input range 0 to 5.0 V (Vrefout)  Electrical angle 0°~28° can be divided into 16 by 4-bit data. Lead angle 0°: LA = 0 V (GND) Lead angle 28°: LA = 5 V (Vrefout)	

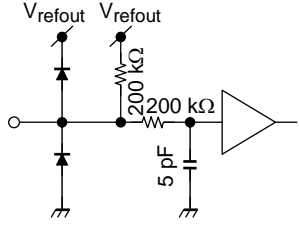
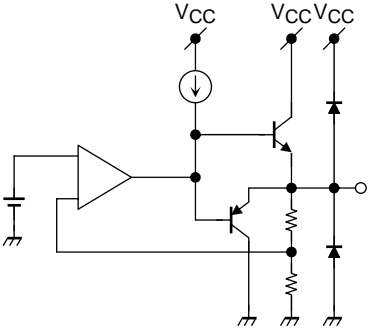
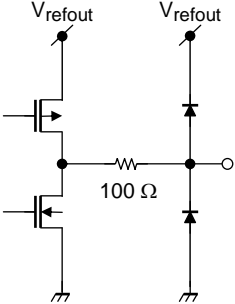
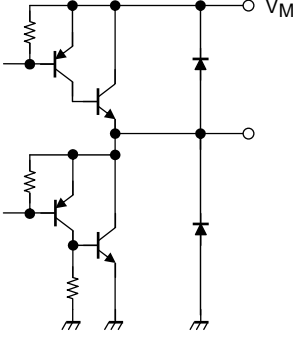
Pin Description	Symbol	Input/Output Signal	Input/Output Internal Circuit
Overcurrent protection signal input	RS	Analog Analog filter 0.5 $\mu$ s (typ.) If RS = 0.5 V (typ.) or higher, UH, VH and WH pin goes low (released at carrier cycle)	
Reference voltage signal output pin	$V_{refout}$	$5.0 \pm 0.5$ V (35 mA) $5.0 \pm 0.3$ V (15 mA)	
Rotational frequency output	FG	Digital Push-pull output ( $\pm 2$ mA (max)) TB6586FG: 1 pulse / electrical angle of 360° TB6586AFG: 3 pulses / electrical angle of 360°	
Energization signal input	UH UL VH VL WH WL	Push-pull output ( $\pm 3$ mA (max))	

**Block Diagram**

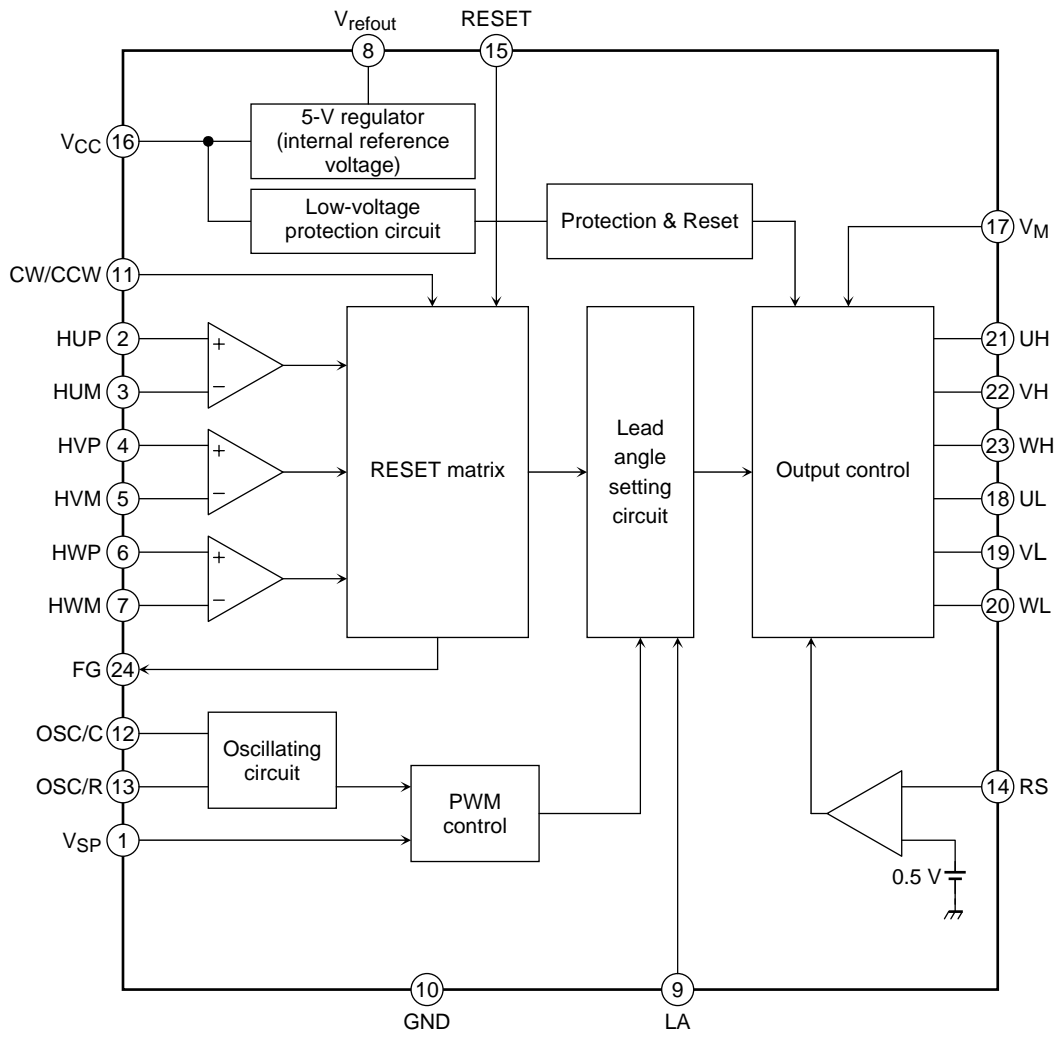

## Absolute Maximum Ratings

Characteristic	Symbol	Rating	Unit
Supply voltage	$V_{CC}$	18	V
	$V_M$	18	
Input voltage	$V_{IN1}$	-0.3 to 8 (Note 1)	V
	$V_{IN2}$	-0.3 to 8.5 (Note 2)	
	LA	-0.3 to $V_{refout} + 0.3$	
Turn-on signal output current	$I_{OUT}$	3	mA
Supply voltage	$P_D$	0.8 (Note2)	W
		1.0 (Note 3)	
Operating temperature	$T_{opr}$	-30 to 85	°C
Storage temperature	$T_{stg}$	-55 to 150	

Note 1: CW/CCW, RESET

Note 2:  $V_{SP}$

Note 3: No heatsink

Note 4: When mounted on a PCB (50 × 50 × 1.6 mm, Cu 10%)

## Operation Conditions ( $T_a = 25^\circ\text{C}$ )

Characteristic	Symbol	Min	Typ.	Max	Unit
Supply voltage	$V_{CC}$	6.5	15	16.5	V
	$V_M$	4.5	—	16.5	V
Oscillation frequency	$F_{osc}$	2	5	8	MHz

## Electrical Characteristics (Unless otherwise specified Ta = 25°C, VCC = 15 V, VM = 5 V)

Characteristic		Symbol	Test Circuit	Test Condition	Min	Typ.	Max	Unit		
Supply current		ICC	—	Vrefout = OPEN, OSC/C = 560 pF, OSC/R = 6.2 kΩ	—	5.5	10	mA		
Output current		IM	—	Drive output (UH, UL, VH, VL, WH, WL) = OPEN	—	0.5	1	mA		
Input current		IIN (LA)	—	VIN = 5 V LA	—	25	50	μA		
		IIN (SP)		VIN = 5 V VSP	—	35	70			
		IIN (RESET)		VIN = 5 V RESET	—	25	50			
		IIN (CW)		VIN = 5 V CW/CCW	—	25	50			
		IIN (RS)		VIN = 0 V RS	—	-25	-50			
Input voltage		VIN1	High	CW/CCW, RESET	Vrefout - 1	—	Vrefout	V		
			Low		0	—	0.8			
		VIN2		—	RESET: 120° turn-on mode	6.0	6.35	6.7	V	
		VRST1		—	CW/CCW: System reset	6.0	6.35	6.7		
		VRST2		—	RESET: Power off reset	2.2	—	Vrefout		
		VSP		H M L	—	PWM ON duty 95%	5.1	5.4	5.7	V
						Refresh → Start motor operation	1.8	2.1	2.4	
Energization OFF → Refresh	0.7					1.0	1.3			
Hall element input	Input sensitivity	VS	—	Differential input	40	—	—	mVpp		
	Common mode	VW		1.5	—	3.5	V			
	Input hysteresis	VH (1)		(Note)	±4.5	±7.5	±10.5	mV		
Input hysteresis voltage		VH (2)	—	RESET: Reset ↔ 120° energization (Note)	—	0.15	—	V		
		VH (3)		CW/CCW: CCW ↔ Reset (Note)	—	0.15	—			
Input delay		TRS	—	RS → Output OFF	—	2.2	—	μs		
Output voltage		VOUT (15) - H	—	IOUT = 3 mA, VM = 15 V	13	14.2	—	V		
		VOUT (15) - L		IOUT = 3 mA, VM = 15 V	—	0.8	1.2			
		VOUT (5) - H		IOUT = 2 mA, VM = 5 V	4.0	4.2	—			
		VOUT (5) - L		IOUT = 2 mA, VM = 5 V	—	0.8	1.0			
		VFG (H)		IOUT = 2 mA FG	4	—	—			
		VFG (L)		IOUT = 2 mA FG	—	—	1.0			
		Vrefout1		IOUT = 15 mA Vrefout	4.7	5.0	5.3			
		Vrefout2		IOUT = 35 mA Vrefout	4.5	5.0	5.5			
Output leakage current		IL (H)	—	VOUT = 0 V	—	0	1	μA		
		IL (L)		VOUT = 15 V	—	0	1			
Electrical current detector		VRS	—	RS	0.46	0.5	0.54	V		
Lead angle correction		TLA (0)	—	LA = 0 V or open, Hall IN = 100 Hz	—	0	—	°		
		TLA (2.5)		LA = 2.5 V, Hall IN = 100 Hz	—	17	—			
		TLA (5)		LA = 5 V, Hall IN = 100 Hz	—	28	—			
VCC monitor		VCC (H)	—	Output start operation point	5.7	6.0	6.3	V		
		VCC (L)		No output operation point	4.7	5.0	5.3			
		VH (4)		Input hysteresis width (Note)	—	1.0	—			

Characteristic	Symbol	Test Circuit	Test Condition	Min	Typ.	Max	Unit
PWM oscillator frequency (carrier frequency)	F <sub>C</sub> (20)	—	OSC/C = 560 pF, OSC/R = 6.2 kΩ	18	20	22	kHz
	F <sub>C</sub> (18)	—	OSC/C = 470 pF, OSC/R = 8.2 kΩ	16.2	18	19.8	
Output duty (max)	T <sub>on</sub> (max)	—	OSC/C = 560 pF, OSC/R = 6.2 kΩ, V <sub>SP</sub> = 5.7 V	92	95	98	%

Note: Pre-shipment testing is not performed.



## Functional Description

### 1. Basic operation

At startup, the motor runs at 120° energization. When the position detection signal reaches a revolution count of  $f_s = 5$  Hz or higher, the rotor position is extrapolated from the position detection signal and output is activated using the lead angle based on the LA signal.

Startup - 5 Hz: 120° energization

$$f_s = f_{osc} / (120 \times 2^5 \times 2^8)$$

5 Hz or higher: 120° energization or 150° energization \* Approximately 5 Hz if  $f_{osc} = 5$  MHz.

\*: At 5 Hz or higher, operation is performed in accordance with commands from RESET and LA pins.

When the motor is running at 5 Hz or lower and in reverse (in accordance with the timing chart), it will be driven at 120° energization for a lead angle of 0°.

### 2. V<sub>SP</sub> voltage command signal function

(1) When voltage instruction is input at  $V_{SP} \leq 1.0$  V:

Output is turned off (gate block protection).

(2) When voltage instruction is input at  $1.0$  V <  $V_{SP} \leq 2.1$  V (refresh operation):

The lower transistor is turned on at a regular (carrier) cycle. (ON duty:  $T_{on} = 18/f_{osc}$ )

(3) When a voltage instruction is input at  $V_{SP} > 2.1$  V:

The drive signal is output using the energization method configured using the RESET pin.

Note: At startup, to charge the upper transistor gate power supply, turn the lower transistor on for a fixed time with  $1.0$  V <  $V_{SP} \leq 2.1$  V.

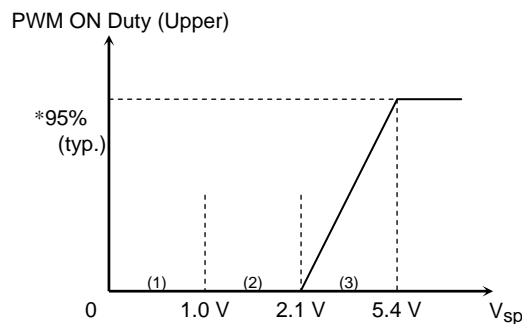

\*: The maximum ON duty is  $T_{on} = 95\%$  (typ.) when  $V_{SP} = 5.4$  V (typ.).

Example: If  $f_{osc} = 5$  MHz, then ON time = 48  $\mu$ s (typ.) ( $f_c = 19.8$  kHz)

If  $f_{osc} = 4$  MHz, then ON time = 60  $\mu$ s (typ.) ( $f_c = 15.9$  kHz)

### 3. Function to stabilize the bootstrap voltage

The product is equipped with a bootstrap capacitor charging function that supports the output level of the bootstrap method.

(1) If the  $V_{SP}$  input current is  $1.0$  V <  $V_{SP} \leq 2.1$  V, the ON signal is output to the lower phase (UL, VL, WL) based on the carrier cycle. If the output waveform is upper phase (UH, VH, WH), the OFF signal (Low) is output.

Output Waveform



Magnified view

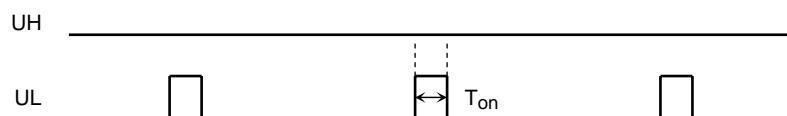

$$T_{on} = 18/f_{osc}$$

Example:  $f_{osc} = 5$  MHz  $T_{on} = 3.6$   $\mu$ s

- (2) If the  $V_{SP}$  input current is  $2.1\text{ V} < V_{SP}$  and the Hall signal is 5 Hz or less, the upper phase (UH, VH, WH) will perform 120° energization at a PWM that complies with the  $V_{SP}$ ; and the lower phase (UL, VL, WL) will operate at 120° energization, performing refresh operation based on the OFF timing. (The same drive is executed during “headwind” operation as well.)

Example Output Waveform

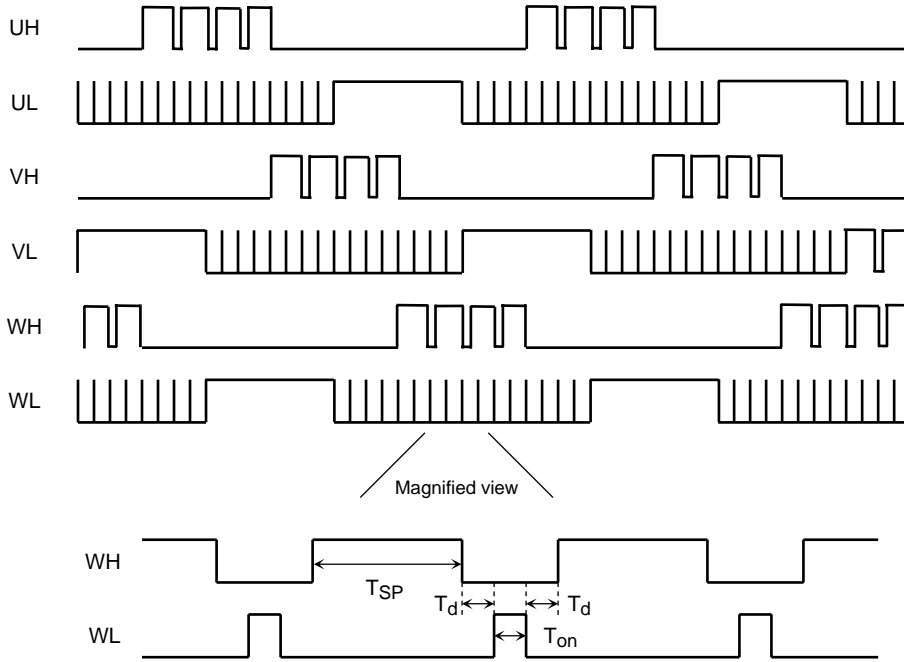

$T_{SP}$ : Variable depending on the  $V_{SP}$  (the figure above being applicable when  $V_{SP} = 5.4\text{ V}$  (typ.));  $T_{on} = 18/f_{osc}$ ;  $T_d = 18/f_{osc}$

\*: The lead angle correction (LA pin) function does not operate when the Hall signal is 5 Hz or less. The lead angle correction function also does not operate when in a reverse detection state.

**4. Correcting the lead angle**

The lead angle can be corrected in the turn-on signal range from 0 to 28° in relation to the induced voltage. Analog input from the LA pin (0 V to 4.3 V divided by 16):

0 V = 0°

4.3 V or higher = 28°

Sample Evaluation Results

Steps	LA (V)	Lead Angle (°)
1	0.00	0.00
2	0.05	1.93
3	0.28	3.79
4	0.59	5.65
5	0.89	7.54
6	1.21	9.43
7	1.52	11.29
8	1.83	13.15
9	2.14	15.08
10	2.45	16.87
11	2.75	18.73
12	3.06	20.66
13	3.37	22.55
14	3.68	24.37
15	3.99	26.16
16	4.30	28.09

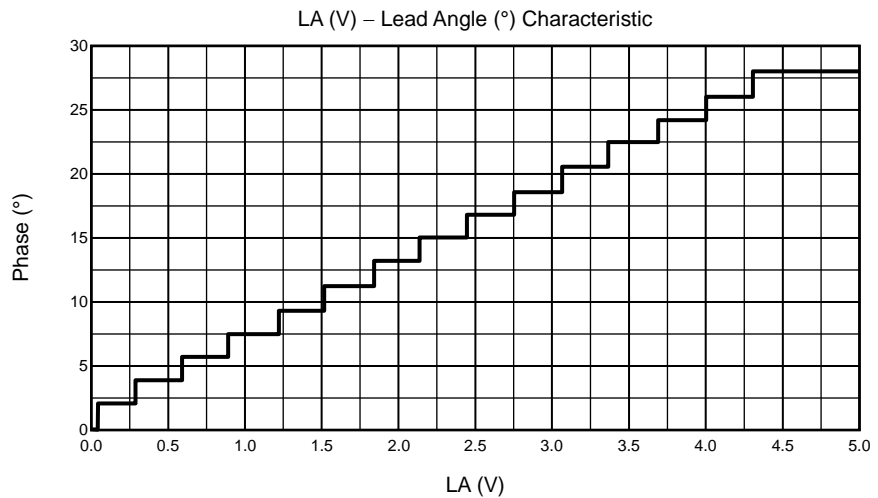

**5. Setting the carrier frequency**

This function involves setting the triangular wave cycle (carrier cycle) necessary for generating PWM signals.

Carrier frequency:  $f_c = f_{osc}/252$  (Hz)       $f_{osc}$  = reference clock (crystal oscillation)

Example: If  $f_{osc} = 5$  MHz, then  $f_c = 19.8$  kHz  
 If  $f_{osc} = 4$  MHz, then  $f_c = 15.9$  kHz

**6. Position detection pin**

The common-mode voltage range is  $V_W = 1.5$  to  $3.5$  V. The input hysteresis is  $V_H = 7.5$  mV (typ.).

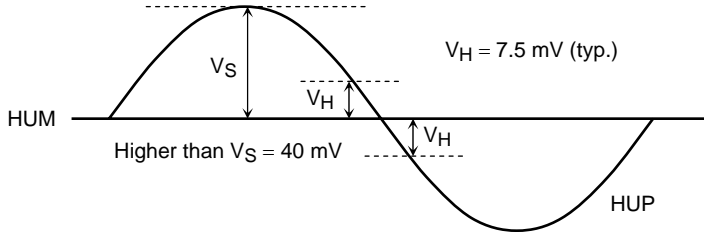

**7. Revolution pulse output pin (the difference between TB6586FG and TB6586AFG)**

This pin outputs the revolution pulses based on the Hall signal. The TB6586FG outputs one (1) pulse / electrical angle and the TB6586AFG outputs three (3) pulses / electrical angle. In the case of the TB6586FG, this pulse is generated via the U phase Hall signal. For a Hall element, the pulse is converted to digital and then output. For a Hall IC, it is output in the equivalent waveform. In the case of the TB6586AFG, the up-down edges of the U, V and W phase (respectively) are combined and then generated.

Example: Number of FG pulses for an 8-pole motor:  
 • TB6586FG: 4 pulses per revolution (4 ppr)  
 • TB6586AFG: 12 pulses per revolution (12 ppr)

**FG Signal Timing Chart**

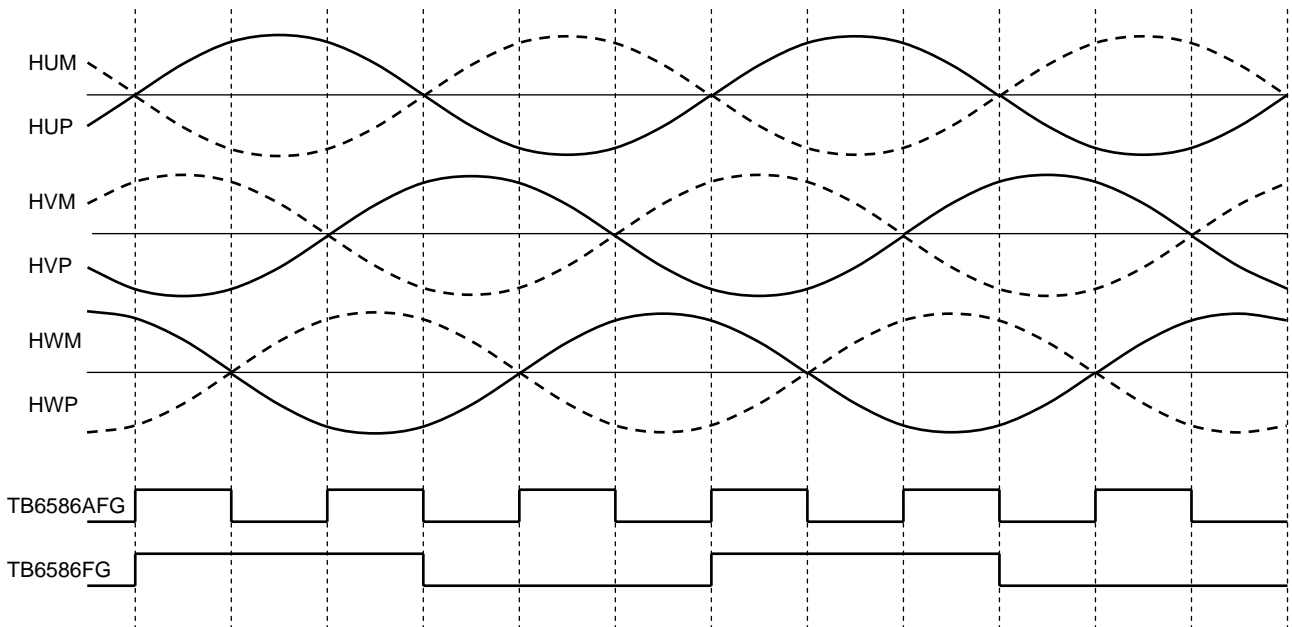

## 8. Protecting input pin

### (1) Overcurrent protection (Pin RS)

When the DC link current exceeds the internal reference voltage, this pin performs gate block protection. Overcurrent protection is restored for each carrier frequency.

The pin is equipped with a filter (analog filter = 0.5  $\mu$ s (typ.)) that prevents malfunctioning due to external noise.

### (2) Position detection signal error protection

When the position detection signals are either all High, Low or Open, all the output is turned OFF (all phases Low). Anything else results in a restart.

### (3) Low power voltage protection (VCC power monitor)

If the operation voltage range is exceeded when the power is being turned on or off, all the output is turned Low to prevent short circuit damage to the power element. Also, if 2.1 V or higher is input via the VSP pin, and if the motor is not rotating (Hall signal = 5 Hz or less), then normal drive is restored after a refresh operation (1.5 ms (typ.)) is performed. However, operations cannot be guaranteed during a power restoration as the circuitry will be unstable when the power is turned on.

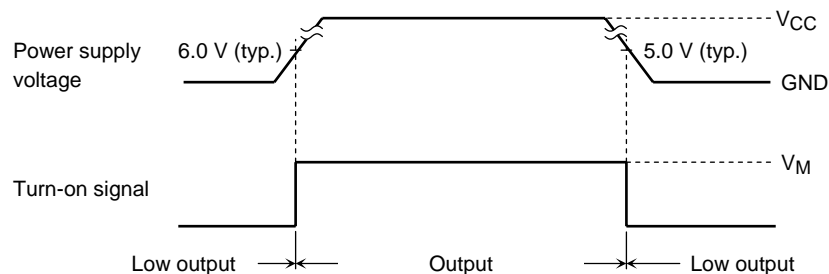

### (4) Output pulse width restriction

To prevent damage to the output driver (externally attached), the drive output signals (UH, VH, WH, UL, VL, WL) are restricted from being output at a pulse width of 1  $\mu$ s or less.

### (5) Reset circuit

When 1.7 V (typ.) or more is input to the RESET pin, a reset will be performed with all output phases being turned off (i.e., all phases Low). Output is also turned off if 6.35 V (typ.) or more is supplied to the CW/CCW pin. However, do not use this method as the restoration obtained from it is unstable.

- RESET pin: Output off reset

All output phases are turned Low and the externally connected power element is stopped. When 1.7 V or less is input, the power is restored. During the restoration, if 2.1 V or more is not input to the VSP pin, and if the motor is not rotating (Hall signal = 5 Hz or less), a refresh operation will be performed (1.5 ms (typ.)). Normal drive will then be restored.

During the reset, the internal counter continues to operate and the FG signal continues to be output.

- CW/CCW pin: System reset

All output phases are turned Low and the externally connected power element is stopped. Restoration takes place at an input of 6.35 V (typ.). However, operation after this kind of system reset is unstable.

TB6586FG: During a system reset, the FG signal is output in compliance with the U-phase Hall signal.

TB6586AFG: The FG signal is not output during a system reset.

## Timing Chart (CW/CCW = Low, LA = GND)

(The FG signal shown here is for the TB6586AFG.)

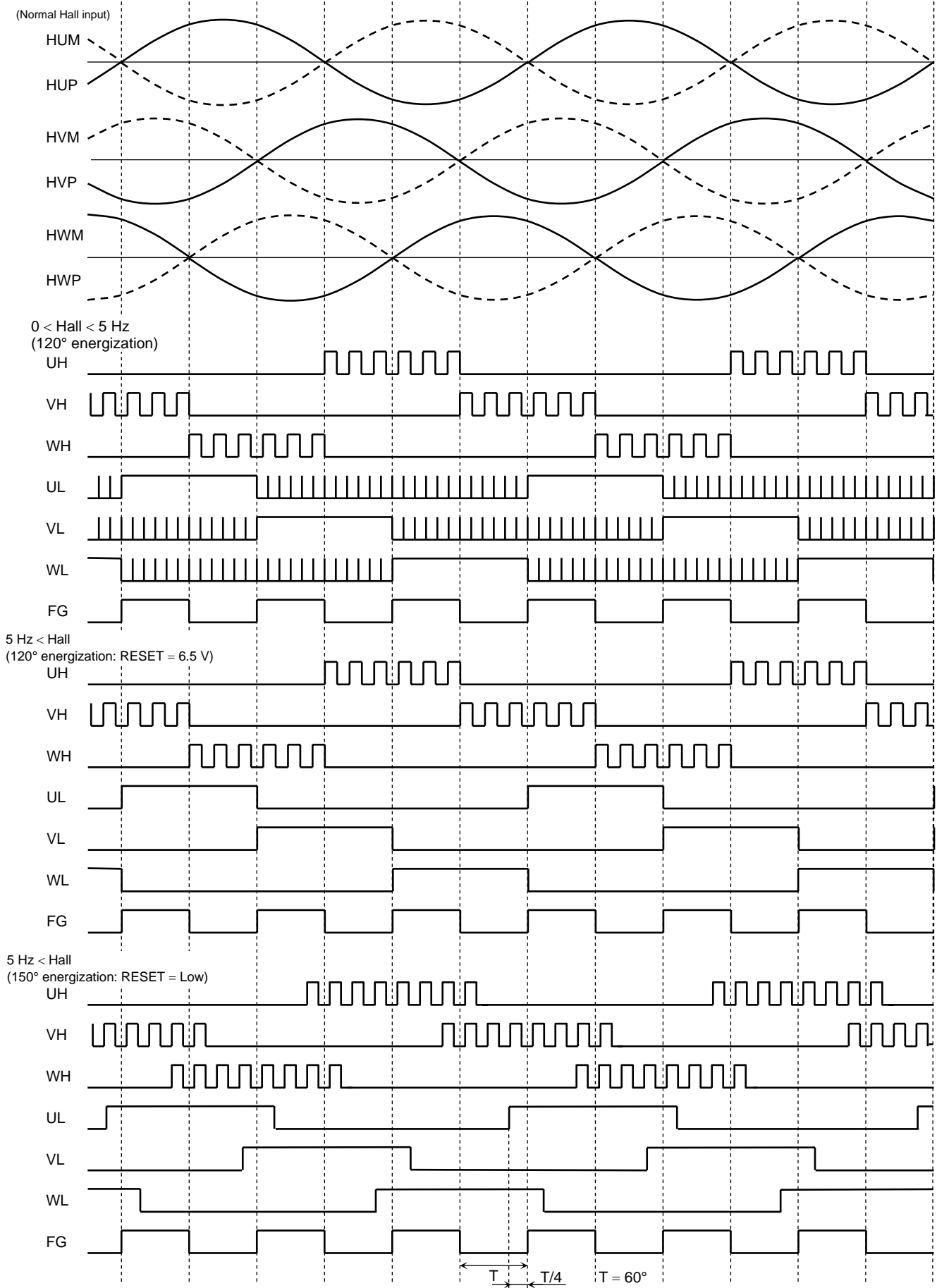

## Timing Chart (CW/CCW = High, LA = GND)

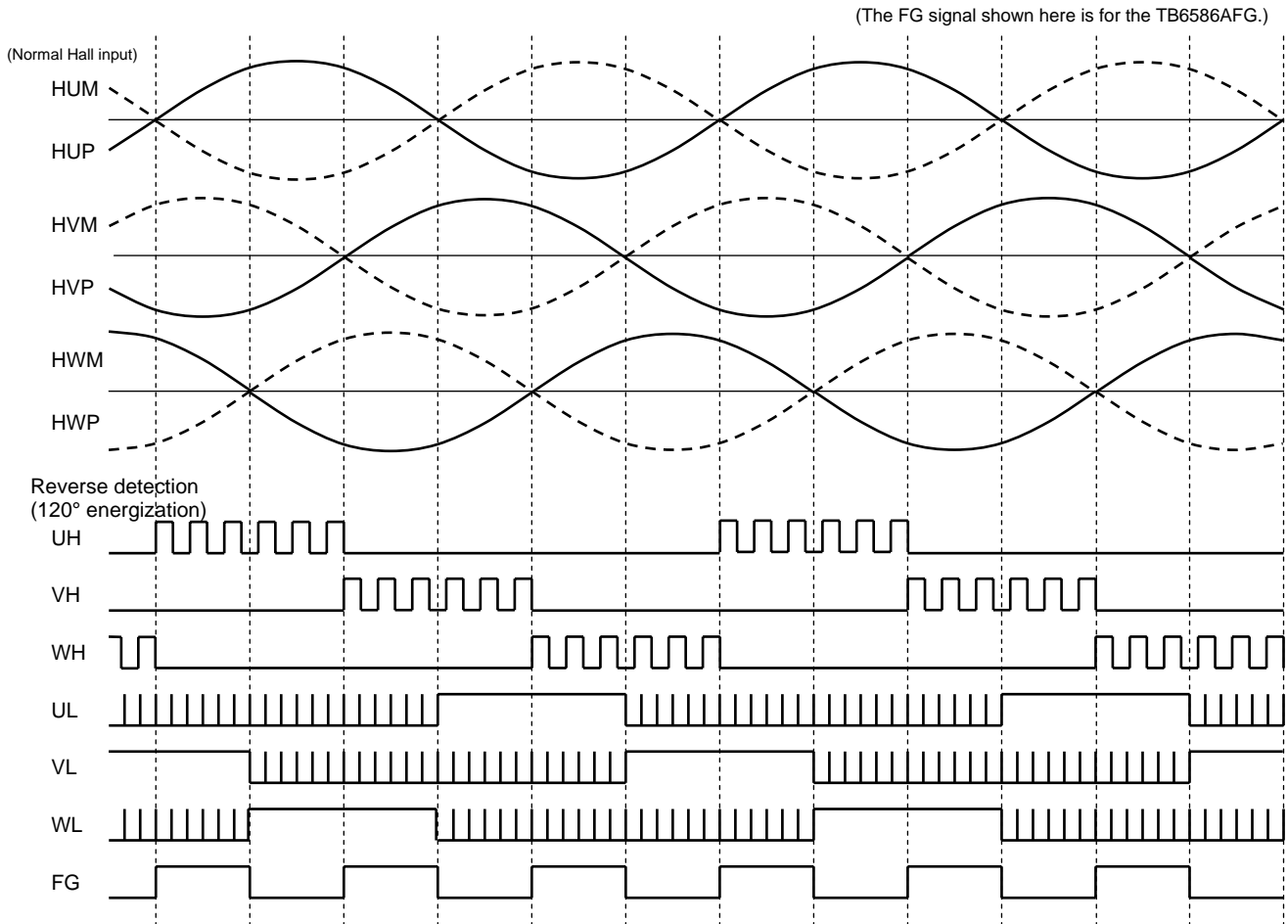

\*: When CW/CCW = Low and a reverse Hall signal is input, it runs at 120° energization for a lead angle of 0° ("headwind" operation).

## Timing Chart (CW/CCW = High, LA = GND)

(The FG signal shown here is for the TB6586AFG.)

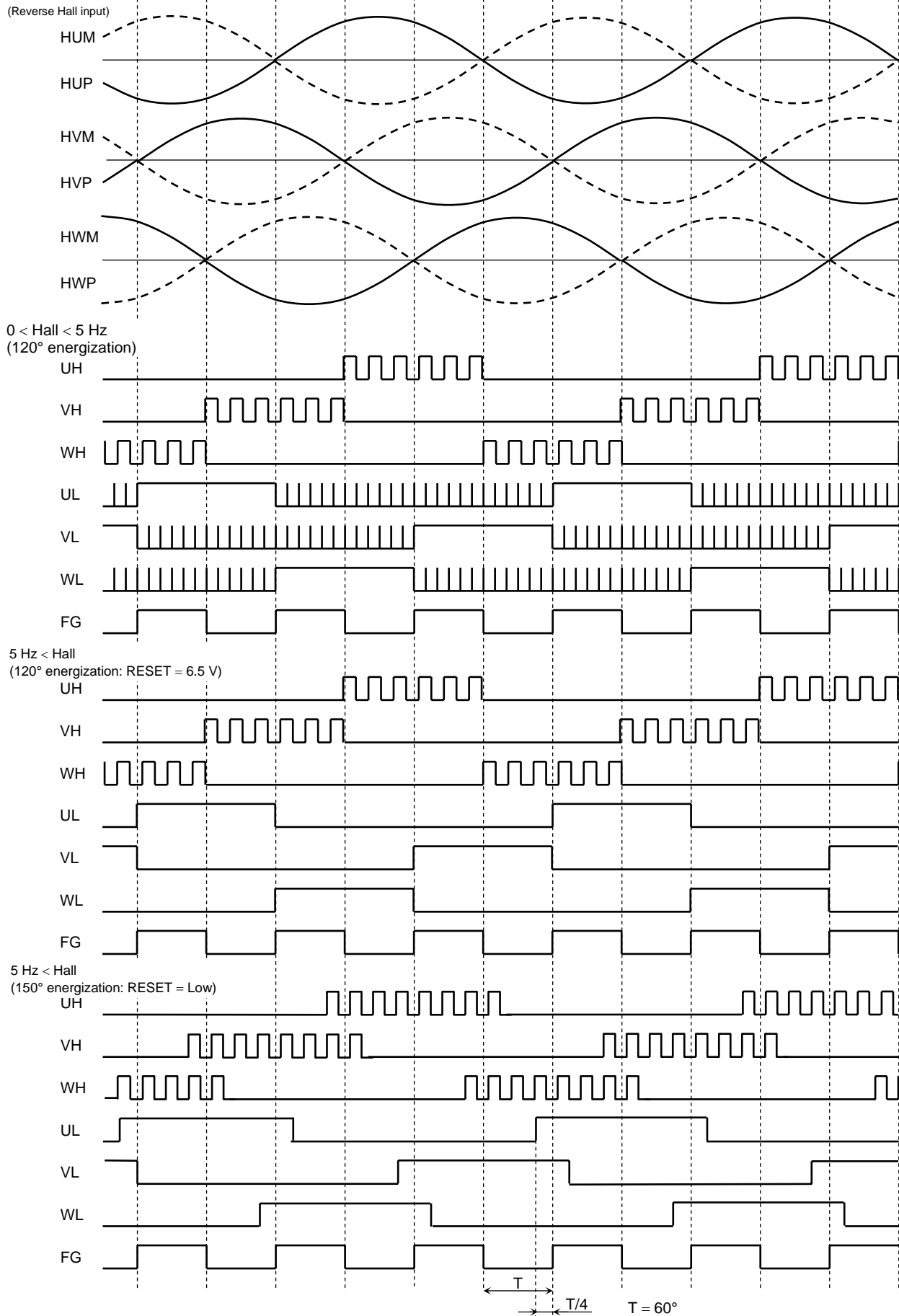

\*: When the Hall signal is 5 Hz or higher, the lead angle function operates in accordance with the LA pin signal.

## Timing Chart (CW/CCW = Low, LA = GND)

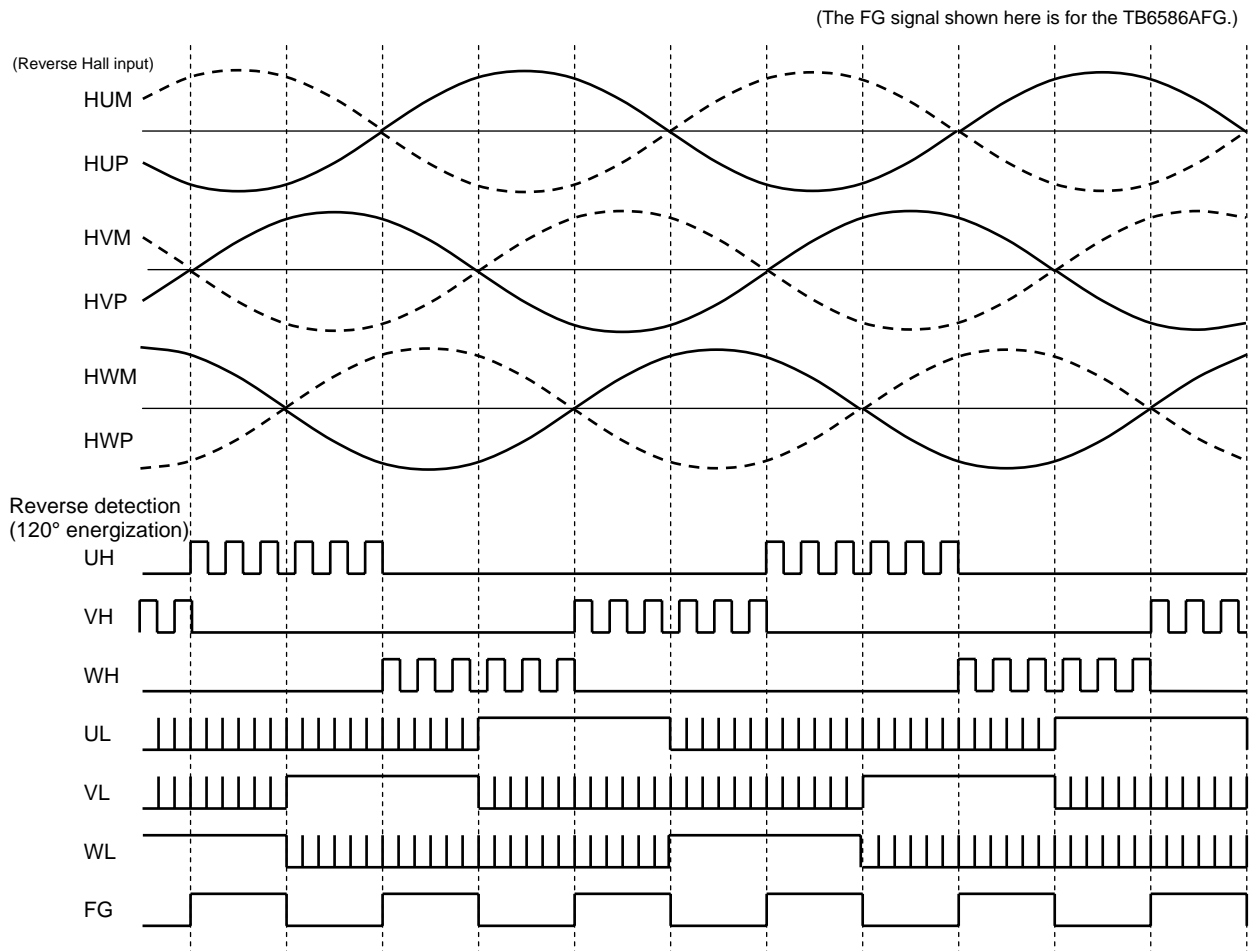

\*: When CW/CCW = Low and a reverse Hall signal is input, the motor runs at 120° energization for a lead angle of 0° ("headwind" operation)



## Example Application Circuit

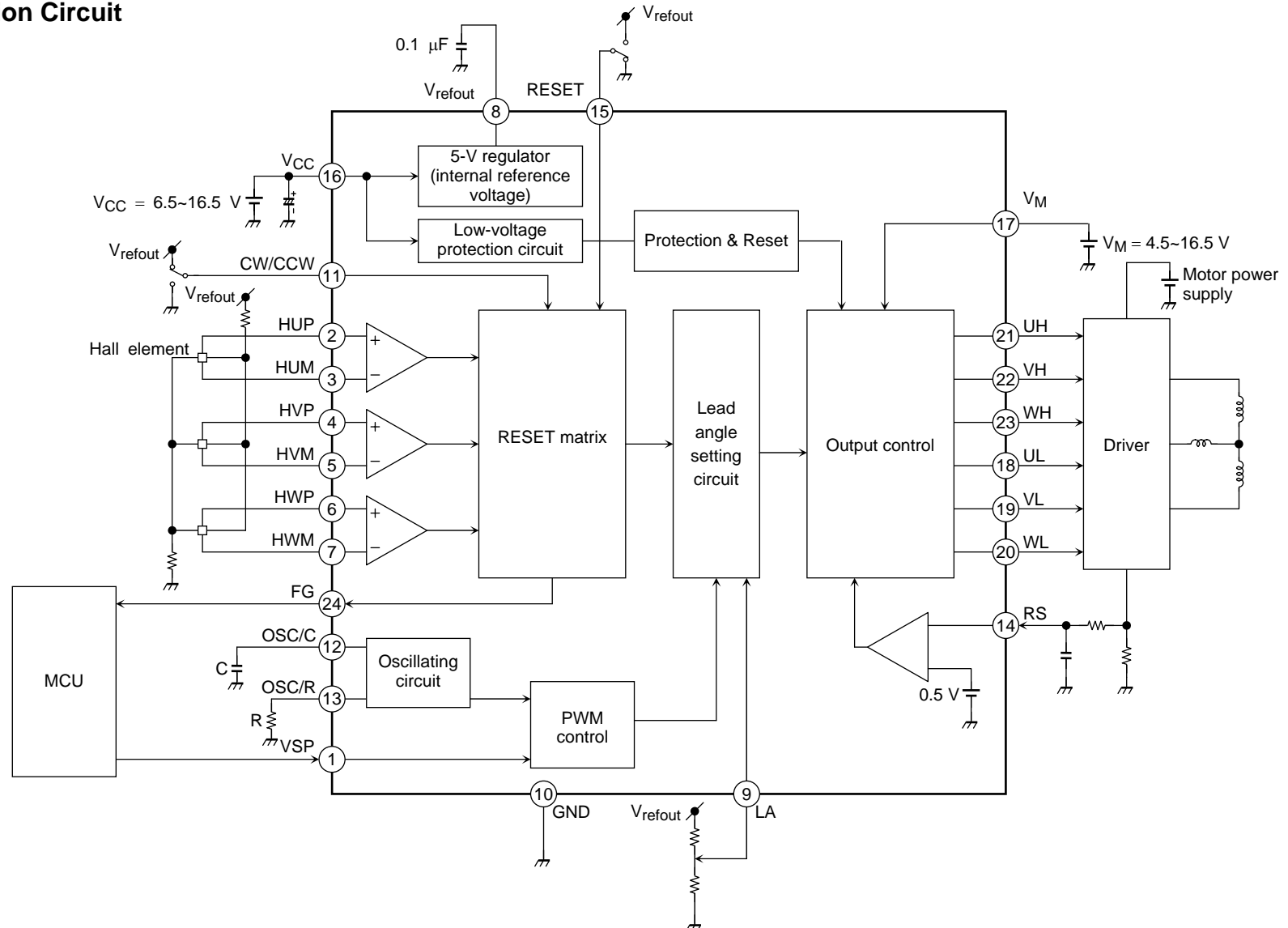

Note: Utmost care is necessary in the design of the output,  $V_{CC}$ ,  $V_M$ , and GND lines since the IC may be destroyed by short-circuiting between outputs, air contamination faults, or faults due to improper grounding, or by short-circuiting between contiguous pins. Add overcurrent protection such as a fuse to make the device drive normally should a current exceeding the maximum rating flow in the IC for any reason.

**Package Dimensions**

SSOP24-P-300-1.00B

Unit : mm

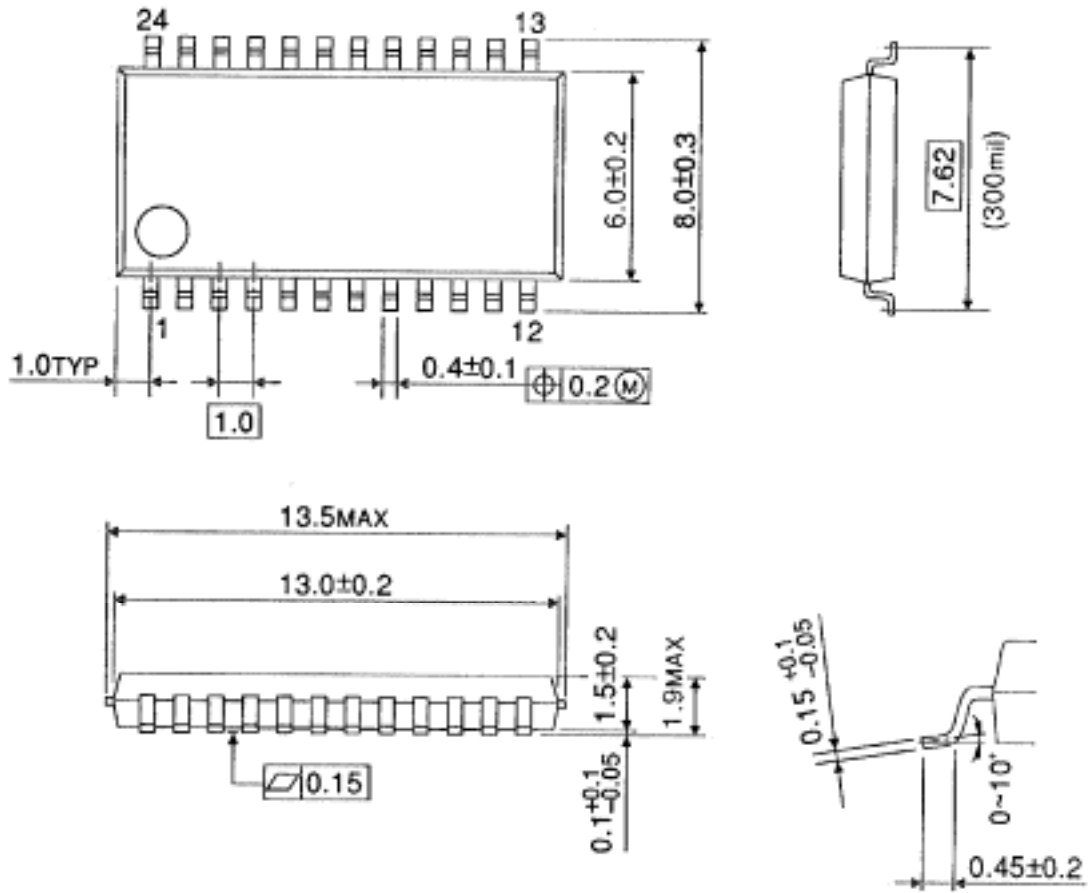

Weight: 0.27 g (typ.)

## Notes on Contents

### 1. Block Diagrams

Some of the functional blocks, circuits, or constants in the block diagram may be omitted or simplified for explanatory purposes.

### 2. Equivalent Circuits

The equivalent circuit diagrams may be simplified or some parts of them may be omitted for explanatory purposes.

### 3. Timing Charts

Timing charts may be simplified for explanatory purposes.

### 4. Application Circuits

The application circuits shown in this document are provided for reference purposes only. Thorough evaluation is required, especially at the mass production design stage.

Toshiba does not grant any license to any industrial property rights by providing these examples of application circuits.

### 5. Test Circuits

Components in the test circuits are used only to obtain and confirm the device characteristics. These components and circuits are not guaranteed to prevent malfunction or failure from occurring in the application equipment.

## IC Usage Considerations

### Notes on handling of ICs

[1] The absolute maximum ratings of a semiconductor device are a set of ratings that must not be exceeded, even for a moment. Do not exceed any of these ratings.

Exceeding the rating(s) may cause the device breakdown, damage or deterioration, and may result injury by explosion or combustion.

[2] Do not insert devices in the wrong orientation or incorrectly.

Make sure that the positive and negative terminals of power supplies are connected properly.

Otherwise, the current or power consumption may exceed the absolute maximum rating, and exceeding the rating(s) may cause the device breakdown, damage or deterioration, and may result injury by explosion or combustion.

In addition, do not use any device that is applied the current with inserting in the wrong orientation or incorrectly even just one time.

### Points to remember on handling of ICs

#### Heat Radiation Design

In using an IC with large current flow such as power amp, regulator or driver, please design the device so that heat is appropriately radiated, not to exceed the specified junction temperature ( $T_j$ ) at any time and condition. These ICs generate heat even during normal use. An inadequate IC heat radiation design can lead to decrease in IC life, deterioration of IC characteristics or IC breakdown. In addition, please design the device taking into considerate the effect of IC heat radiation with peripheral components.

**RESTRICTIONS ON PRODUCT USE**

070122EBA\_R6

- The information contained herein is subject to change without notice. 021023\_D
- TOSHIBA is continually working to improve the quality and reliability of its products. Nevertheless, semiconductor devices in general can malfunction or fail due to their inherent electrical sensitivity and vulnerability to physical stress. It is the responsibility of the buyer, when utilizing TOSHIBA products, to comply with the standards of safety in making a safe design for the entire system, and to avoid situations in which a malfunction or failure of such TOSHIBA products could cause loss of human life, bodily injury or damage to property.  
In developing your designs, please ensure that TOSHIBA products are used within specified operating ranges as set forth in the most recent TOSHIBA products specifications. Also, please keep in mind the precautions and conditions set forth in the "Handling Guide for Semiconductor Devices," or "TOSHIBA Semiconductor Reliability Handbook" etc. 021023\_A
- The TOSHIBA products listed in this document are intended for usage in general electronics applications (computer, personal equipment, office equipment, measuring equipment, industrial robotics, domestic appliances, etc.). These TOSHIBA products are neither intended nor warranted for usage in equipment that requires extraordinarily high quality and/or reliability or a malfunction or failure of which may cause loss of human life or bodily injury ("Unintended Usage"). Unintended Usage include atomic energy control instruments, airplane or spaceship instruments, transportation instruments, traffic signal instruments, combustion control instruments, medical instruments, all types of safety devices, etc. Unintended Usage of TOSHIBA products listed in this document shall be made at the customer's own risk. 021023\_B
- The products described in this document shall not be used or embedded to any downstream products of which manufacture, use and/or sale are prohibited under any applicable laws and regulations. 060106\_Q
- The information contained herein is presented only as a guide for the applications of our products. No responsibility is assumed by TOSHIBA for any infringements of patents or other rights of the third parties which may result from its use. No license is granted by implication or otherwise under any patents or other rights of TOSHIBA or the third parties. 070122\_C
- Please use this product in compliance with all applicable laws and regulations that regulate the inclusion or use of controlled substances.  
Toshiba assumes no liability for damage or losses occurring as a result of noncompliance with applicable laws and regulations. 060819\_AF
- The products described in this document are subject to foreign exchange and foreign trade control laws. 060925\_E